

# SPX Hose Pumps

Improve your process performance



Represented by

**POWELL**

EQUIPMENT SALES, INC

(763) 786-2977

[www.powellequipsales.com](http://www.powellequipsales.com)

# Good News . . . a pump with no seals or valves



The Perfect Pump for:

- Corrosives
- Abrasives
- Shear sensitive fluids
- High viscosity fluids
- High density fluids
- Large solids
- Long stringy material

## The positive displacement pump of choice

Watson-Marlow Bredel is the world's largest manufacturer of hose pumps with the widest range of pumps and hose element materials. Today over 75,000 Watson-Marlow Bredel positive displacement hose pumps are working non-stop all around the globe. With operating pressures to 232 psi and flow rates to 350 gpm Watson-Marlow Bredel pumps save time and money by successfully handling the toughest applications, in a broad range of industries including:

- Chemical - corrosive acids, bases, and hydrocarbons
- Water and wastewater treatment - lime, sodium hypochlorite, ferric chloride and sludges
- Paint and pigments - dispersion mill feed, pigment and latex transfer
- Pulp and Paper - dyes, sizing agents, retention aids and titanium dioxide
- Mining and mineral separation - tailing slurries, sludges and reagents
- Ceramics and glass - fine china, brick and roof tiles
- Construction - cement, coatings, spray concrete, colorants and aggregate
- Printing and packaging - varnishes, inks, coatings and adhesives
- Food and beverage - CIP applications, wine, brewery, dairy, bakery, flavorings and additives
- Agriculture - seed coatings, animal vaccines and waste
- Automotive - flock adhesives, lapping compounds and inks
- Textiles - fibers, dyes and acids
- OEM - versions available for system suppliers

## Engineered Simplicity

The pumping action results from alternately compressing and relaxing a machined hose element between the pump housing and the compressing shoes. The fluid ahead of the shoe is pushed towards the discharge while the rebounding hose behind the shoe draws more fluid in. With 100% compression at all times, the pump does not slip, providing unbeatable metering accuracy and pressure performance. With no pump seals, seats or valves, abrasive slurries are no problem. With the fluid contacting only the inner wall of the hose, the pump is perfect for aggressive chemicals.

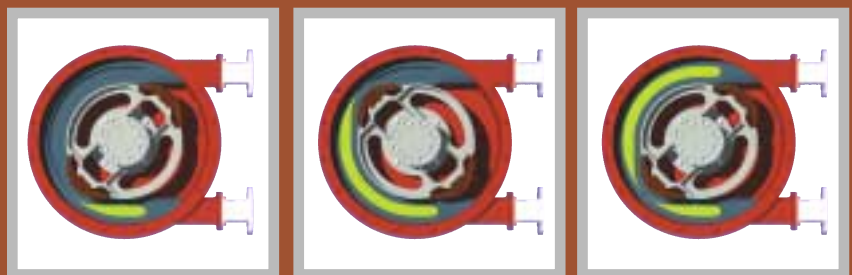

# to wear, clog, or leak.

## The fastest growing pump type

High maintenance diaphragm, rotary lobe, or progressive cavity pumps can't match the rugged, reliable 24/7 dependability of the SPX which:

- Doesn't require expensive ancillary equipment. No check valves, sealing water flush systems, or run dry protection. It's simple to own and operate
- Pumps abrasive slurries, corrosive acids, gaseous liquids, as easily as water - no vapor locking
- Is ideal for high viscosity or shear sensitive product
- Can run dry indefinitely without damage
- Has one wetted component - the hose element. No seals, ball-checks, diaphragms, glands, immersed rotors, stators or pistons to leak, clog, corrode and replace
- Is fully reversible to blow out clogged suction and drain lines safely
- Has a suction lift capability up to 30 feet and is self-priming
- Does not slip, giving true positive displacement for accurate and repeatable metering

## Downtime is money

Save both with the SPX by reducing your maintenance. To completely rebuild an SPX all you need is a wrench, a hose, and a few minutes. Drain the lubricant, unbolt the flanges, replace the old hose and you're back up and running. No complex parts lists, no special tools, and no need to bring the pump to a maintenance shop.

## SPX - The apex of pump evolution

With over 50 years experience, Watson-Marlow Bredel leads the way in hose pump technology, engineering the new standard for hose pumping with its unique SPX direct-coupled design. The SPX combines the small footprint of close-coupled pumps with the reliability and ease of maintenance of long-coupled designs.

While close-coupled pumps are extremely compact, this out-of-date technology still used by other hose pump manufacturers relies on the gearbox to seal the pump housing and support the heavy overhung load of the pump rotor. While close-coupled pump competitors offer optional long-coupled pumps to improve gearbox and bearing life this comes at the cost of substantially increased footprint and the added complexity of coupling alignment and maintenance.

The SPX direct-coupled design contains heavy duty rotor bearings within the pump rotor, eliminating any overhung load. Ultra compact SPX high-torque planetary gearing then aligns directly to the pump housing and is fully protected by an innovative buffer zone. No other pump achieves the reliability, simplicity, and compactness of the SPX hose pump.

## Compare the advantages of SPX

Comparative advantages	Long-coupled	Close-coupled	SPX direct-coupled
Ease of maintenance	•		•
Protected gearbox - lubricant seal in pumphead	•		•
Reliability - bearings in pumphead	•		•
Compact footprint		•	•
Faster installation - no drive alignment		•	•
<b>Total</b>	<b>3</b>	<b>2</b>	<b>5</b>

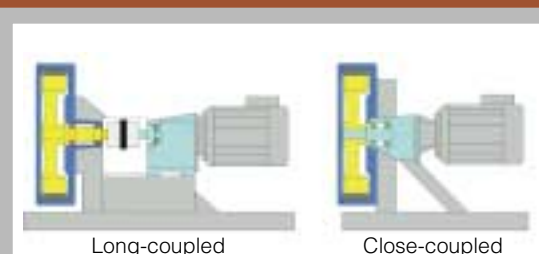
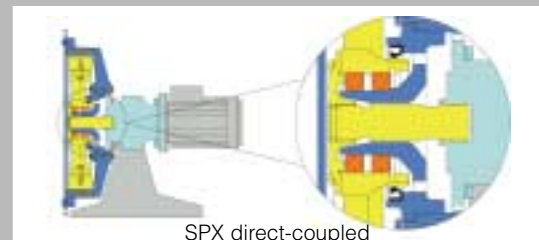

# The hose is the key

The machined hose element is the single most vital component for the performance, durability, and efficiency of the hose pump. To ensure perfect compression and consistent, reliable performance, Watson-Marlow Bredel manufactures hose elements from high quality compounded rubbers, reinforced with four individual layers of braided nylon and finished by high precision machining. Perfect compression eliminates slip which, in other pumps, can destroy shear sensitive product, reduce metering accuracy, or allow abrasive slurries to wreak havoc on wetted parts. Watson-Marlow Bredel engineers hose elements to meet the flow, pressure and temperature characteristics of your toughest applications.

We are the only hose pump manufacturer to machine our own hose elements. No other competitors take this care.



Because even a 1mm variation in wall thickness can impact hose life by 25%, every hose element is precision machined to ensure repeatable performance.



## Hose Construction

The essential component of high-performance hose pumps is a hose that is constructed of layers of rubber reinforced by winding several layers of nylon cords. The inner and outer layers are extruded. The inner layer is available in a range of rubber compounds. After the hose is constructed, it is then machined. Machining is the final step in hose manufacture and is critical to insure that exact tolerances are held.

- 1 Inner layer in various types of rubber**
- 2 Reinforced with layers of nylon**
- 3 Outer layer precision-machined**
- 4 Rough outer surface before machining**

## Designed to perfection

Watson-Marlow Bredel is on the cutting edge of technology to engineer, manufacture and test our pumps.

**Innovation:** As the global leader in hose pumps, we pride ourselves on new ideas and innovative products that bring the benefits of hose pumps to our customers in an ever expanding range of applications. For example, retractable pressing shoes bring ultimate clean-in-place capability. And new hose materials have now made our pumps impervious to tough hydrocarbons - once off limits to hose pumps.

**Design:** Using tools like finite element analysis (FEA), we design our hose elements to perfection - right down to the position of the reinforcing layers, angles and thickness of the cord reinforcement, and the thickness of the rubber. Everything from the geometry of the pressing shoe to the pump housing is engineered to optimize the performance of the hose element.

**Production:** Unique in the world, Watson-Marlow Bredel's state-of-the-art automated hose grinding facility machines every hose within fine tolerances - guaranteeing proper compression for efficiency and longevity. At our ISO9001.2000 factory, each pump and hose element is constructed to the most rigorous quality controls standards.



At our research and design lab, pumps are running non-stop every day to enhance the performance of the best hose pumps on the market today, and develop new innovations for the future.

## Precision hose elements ensure

- Tight tolerances for low stress on bearings
- Perfect compression for long life
- Excellent suction performance - 30 ft. Suction lift
- High pressure capability - 232 psi
- Repeatable volumetric accuracy to +/- 1%
- Consistent capacity independent of varying suction and discharge conditions
- Exceptional performance when handling high viscosity products

## Hose Options



### NATURAL RUBBER (NR)

Outstanding abrasion resistance. Generally resistant to diluted acids and alcohols.

Max. fluid temp 176°F  
Min. fluid temp -4°F



### BUNA N (NBR)

Meets FDA and 3A. Resistant to oils, greases, alkalis and detergents.

Max. fluid temp 176°F  
Min. fluid temp 14°F



### EPDM

Excellent chemical resistance, especially to ketones, alcohols and concentrated acids.

Max. fluid temp 194°F  
Min. fluid temp 14°F



### HYPALON® (CSM)

Outstanding chemical resistance to highly concentrated acids and bases

Max. fluid temp 176°F  
Min. fluid temp 14°F

# Performance

How to use the curves:

- |                                      |                                  |
|--------------------------------------|----------------------------------|
| 1 Flow required indicates pump speed | 5 Calculated discharge pressure  |
| 2 Calculated discharge pressure      | 6 Maximum recommended pump speed |
| 3 Net motor power required           |                                  |
| 4 Product temperature                |                                  |

## SPX10

- Max flow: 0.6 gpm
- Capacity: 0.0058 gal/rev
- Max discharge pressure: 110 psi
- Max temperature: 175°F
- Hose diameter: 10 mm
- Port size: 1/2" male NPT or 150# flange
- Hose lube required: 0.06 gallons
- Starting torque: 250 in lbs

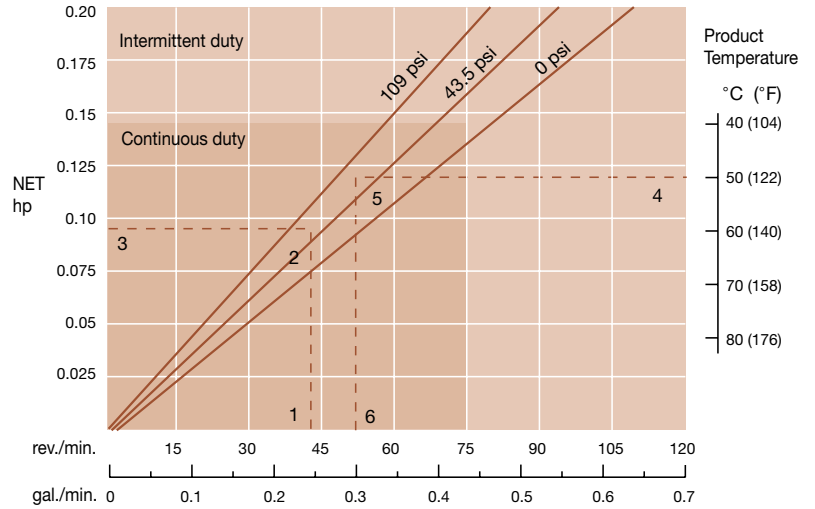

## SPX15

- Max flow: 2.3 gpm
- Capacity: 0.022 gal/rev
- Max discharge pressure: 110 psi
- Max temperature: 175°F
- Hose diameter: 15 mm
- Port size: 3/4" male NPT or 150# flange
- Hose lube required: 0.13 gallons
- Starting torque: 500 in lbs

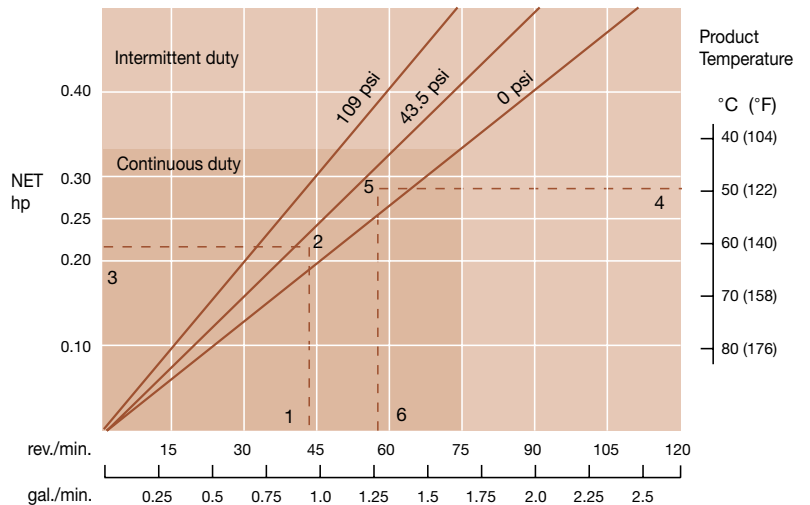

## Solids handling

When GE Plastics, a producer of polycarbonate resin pellets, experienced problems pumping effluent containing waste plastic strips up to 10" long, they switched to Watson-Marlow Bredel hose pumps. The strips were becoming trapped in the double-diaphragm pump the company was using to transport the effluent to a filter press. Constantly blocked, the diaphragm pump was, in effect, acting as a filter. The Watson-Marlow Bredel hose pump transfers the effluent easily, virtually eliminating downtime. It has also improved the effectiveness of the filter press by as much as 35 times.

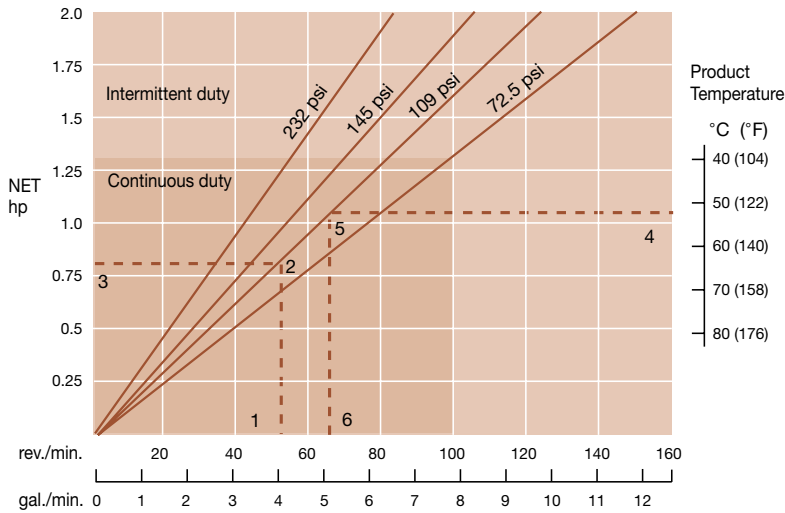

## SPX25

- Max flow: 11 gpm
- Capacity: 0.079 gal/rev
- Max discharge pressure: 232 psi
- Max temperature: 175°F
- Hose diameter: 25 mm
- Port size: 1" 150# flange
- Hose lube required: 0.53 gallons
- Starting torque: 1600 in lbs

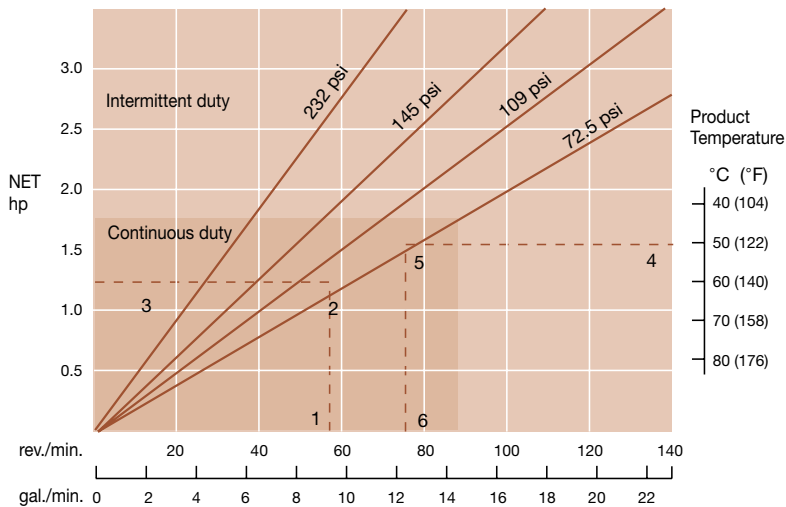

## SPX32

- Max flow: 20 gpm
- Capacity: 0.165 gal/rev
- Max discharge pressure: 232 psi
- Max temperature: 175°F
- Hose diameter: 32 mm
- Port size: 1½" 150# flange
- Hose lube required: 0.8 gallons
- Starting torque: 3000 in lbs

At the Massachusetts Water Resources Authority (MWRA), influent is received through several 4 to 6 mile pipelines under Boston Harbor. After preliminary processing, the influent goes through a scrub down to reduce hydrogen sulfide content from as much as 250 ppm to less than 0.1 ppm. Watson-Marlow Bredel hose pumps are used in this process to transfer and meter sodium hypochlorite, sodium hydroxide, and sodium bisulfate. After experiencing high downtime, high maintenance costs, and disappointing performance with diaphragm, PC and other types of pumps, plant engineers switched the process over to the Watson-Marlow Bredel pumps.



## Chemical metering

# Performance

How to use the curves:

- 1 Flow required indicates pump speed
- 2 Calculated discharge pressure
- 3 Net motor power required
- 4 Product temperature
- 5 Calculated discharge pressure
- 6 Maximum recommended pump speed

## SPX40

- Max flow: 39 gpm
- Capacity: 0.351 gal/rev
- Max discharge pressure: 232 psi
- Max temperature: 175°F
- Hose diameter: 40 mm
- Port size: 1½" 150# flange
- Hose lube required: 1.3 gallons
- Starting torque: 4000 in lbs
- CIP version available for easy clean-in-place

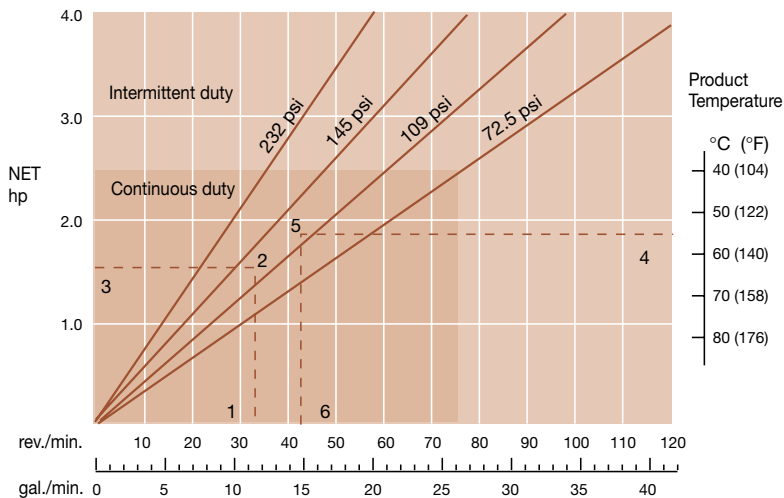

## SPX50

- Max flow: 69 gpm
- Capacity: 0.766 gal/rev
- Max discharge pressure: 232 psi
- Max temperature: 175 °F
- Hose diameter: 50 mm
- Port size: 2" 150# flange
- Hose lube required: 2.6 gallons
- Starting torque: 10,000 in lbs
- CIP version available for easy clean-in-place

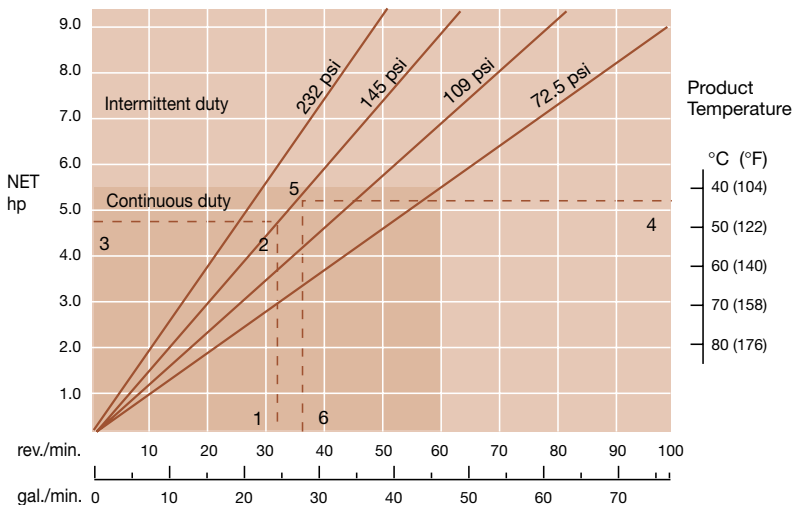

## Abrasive slurries

A leading US brewer had been using diaphragm pumps to meter a highly abrasive diatomaceous earth slurry but was experiencing high downtime due to abrasive wear. The brewer replaced these pumps with Watson-Marlow Bredel hose pumps, dramatically reducing maintenance and all but eliminated downtime. Based on this success, the brewer installed 6 hose pumps to transfer an abrasive slurry of waste yeast. The pumps replaced rotary lobe pumps which required excessive maintenance to replace mechanical seals and lobes. The brewer then replaced their live yeast pumps with CIP hose pumps for easy cleanability!

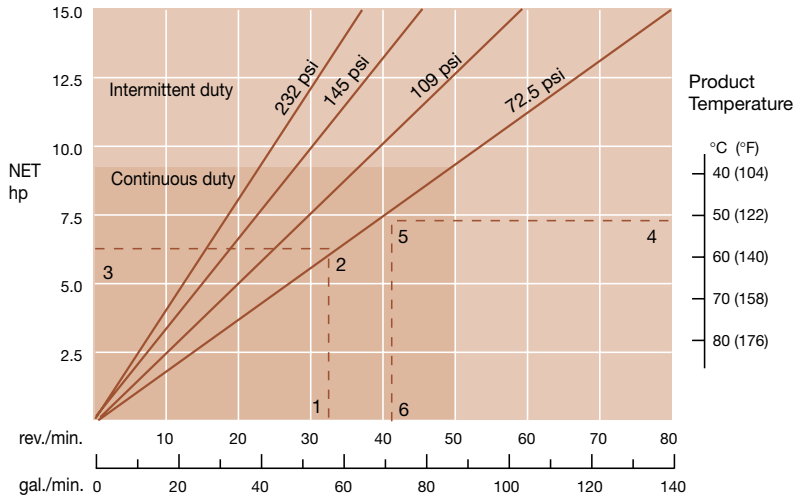

## SPX65

- Max flow: 124 gpm
- Capacity: 1.77 gal/rev
- Max discharge pressure: 232 psi
- Max temperature: 175°F
- Hose diameter: 65 mm
- Port size: 2½" 150# flange
- Hose lube required: 5.3 gallons
- Starting torque: 12,000 in lbs

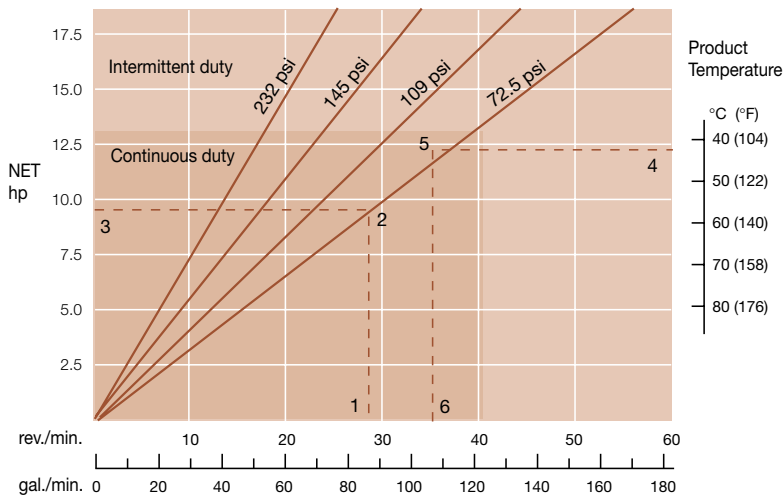

## SPX80

- Max flow: 155 gpm
- Capacity: 3.09 gal/rev
- Max discharge pressure: 232 psi
- Max temperature: 175°F
- Hose diameter: 80 mm
- Port size: 3" 150# flange
- Hose lube required: 10.6 gallons
- Starting torque: 20,000 in lbs

A canning operation located near San Francisco uses a Watson-Marlow Bredel hose pump to transfer peaches from holding tanks to its canning line. The pumps transfer the peaches at a rate of 9 tons per hour. The company had been using centrifugal pumps, but was experiencing a high percentage of damaged peaches. The soft pumping action of the SPX pump eliminates shear and has dramatically reduced the amount of damaged or unacceptable produce. The company also likes the dependability, low maintenance and ability of the pump to run 24/7 throughout the entire canning season.



Shear sensitive

# Performance

How to use the curves:

- |                                      |                                  |
|--------------------------------------|----------------------------------|
| 1 Flow required indicates pump speed | 5 Calculated discharge pressure  |
| 2 Calculated discharge pressure      | 6 Maximum recommended pump speed |
| 3 Net motor power required           |                                  |
| 4 Product temperature                |                                  |

## SPX100

- Max flow: 232 gpm
- Capacity: 5.28 gal/rev
- Max discharge pressure: 232 psi
- Max temperature: 175°F
- Hose diameter: 100 mm
- Port size: 4" 150# flange
- Hose lube required: 15.8 gallons
- Starting torque: 40,000 in lbs

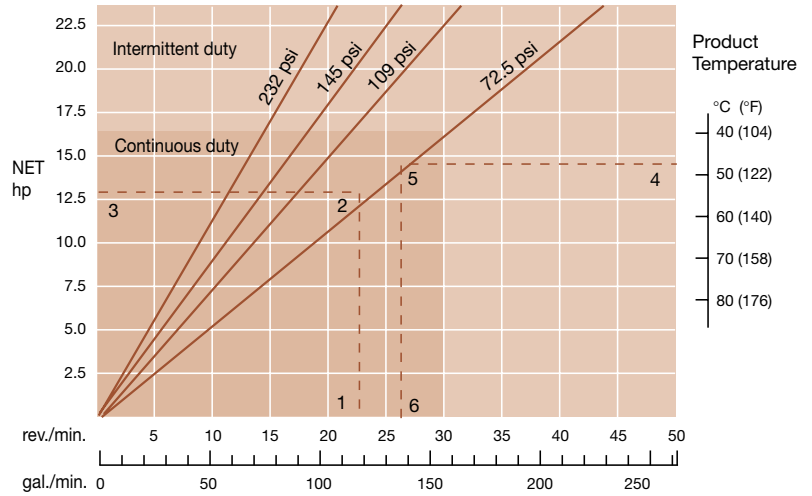

## Duplex SPX100

- Max flow: 400 gpm
- Capacity: 10.56 gal/rev
- Max discharge pressure: 232 psi
- Max temperature: 175°F
- Hose diameter: 100 mm
- Port size: 6" 150# flanged manifold
- Hose lube required: 31.6 gallons
- Starting torque: 80,000 in lbs

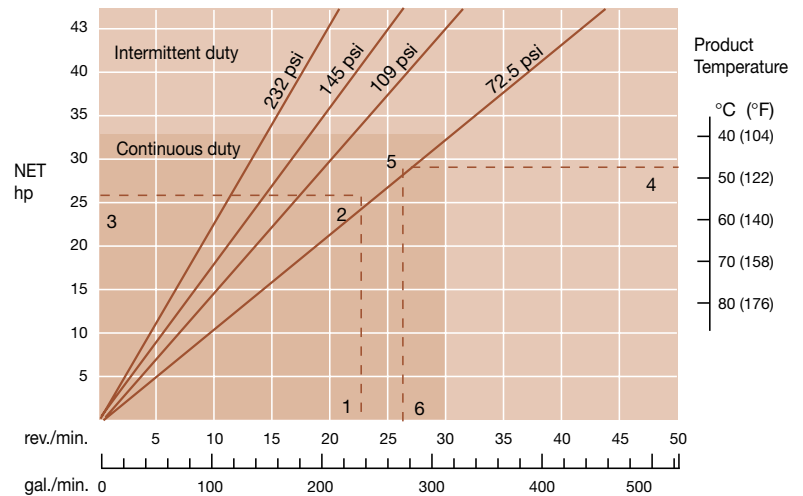

## High flow

A large Texas construction company needed several pumps to transfer a cement mixture containing water, sand and sulfate cellulose at pressures of 200 psi and flow rates of 300 gpm. We recommended a unique duplex hose pump, which has two pumpheads mounted on a single drive. With the pump shoes staggered at 90 degree intervals, the pump is capable of producing higher flow rates than a single pump, but with much smaller power and space requirements than two pumps. As an added benefit, we also offer many color and coating options to meet your specifications.

# Dimensions

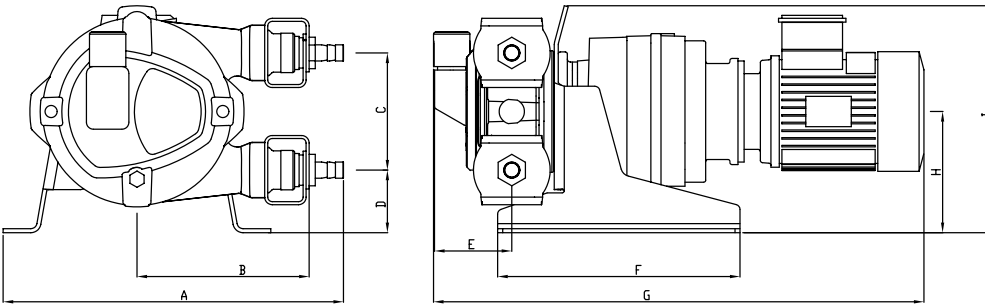

Model	A	B	C	D	E	F	G*	H	I	Approx. Wt. (lbs)
SPX10	13.50	6.73	4.56	2.44	3.07	9.45	24.79	4.72	8.86	75
SPX15	17.09	9.06	7.68	2.48	3.23	9.84	25.97	6.30	11.97	105



**SPX10 – SPX15**

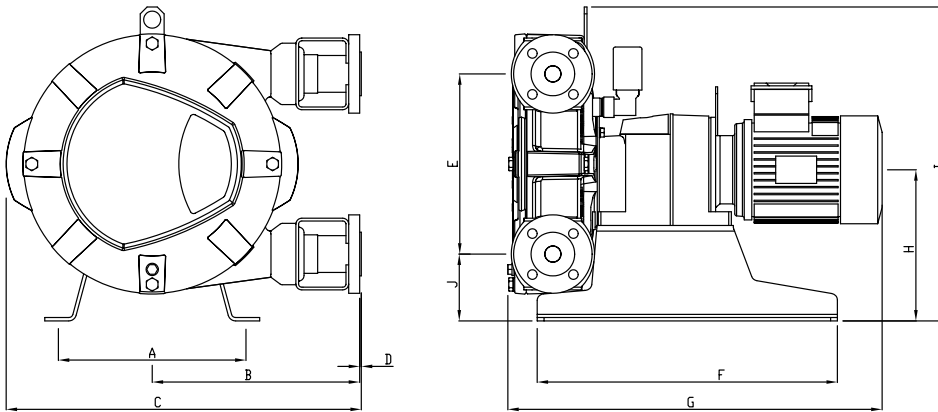

Model	A	B	C	D	E	F	G*	H	I	J	Approx. Wt. (lbs)
SPX25	10.98	11.97	20.51	0.1	10.39	17.31	28.62	8.72	18.11	3.86	165
SPX32	12.76	14.79	24.84	0.1	12.99	20.08	30.6	10.24	21.18	3.86	290



**SPX25 – SPX32**

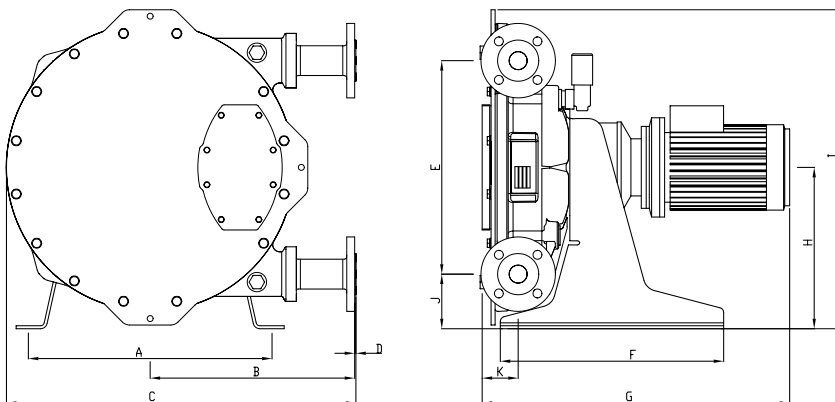

Model	A	B	C	D	E	F	G*	H	I	J	K	Approx. Wt. (lbs)
SPX40	19.3	16.2	27.7	0.1	16.9	17.7	31.12	12.8	24.2	4.3	2.9	400
SPX50	24.4	18.7	33.0	0.1	21.8	22.7	35.4	16.5	31.8	5.6	3.3	700
SPX65	26.8	22.8	41.7	0.1	29.4	25.6	35.8	20.7	40.8	6.0	4.1	1123
SPX80	35.4	27.6	49.4	0.2	34.5	33.5	49.56	24.4	47.9	7.2	4.9	1875
SPX100	41.3	32.1	57.9	0.2	41.0	35.5	52.36	28.3	55.7	7.8	5.9	2900



**SPX40 – SPX100**

\*This dimension will vary depending on drive selection.

**United States of America**  
**Telephone 800 282 8823**  
**Fax: 978 658 0041**  
**Email support@wmbpumps.com**

**Brazil**  
 Telephone +55 11 4616 0404  
 Fax: +55 11 4616 0403  
 Email info4brazil@watson-marlow.com

**Belgium**  
 Telephone +32 (0) 2 481 60 57  
 Fax: +32 (0) 2 481 60 58  
 Email info@watson-marlow.be

**China**  
 Telephone +86 21 6485 4898  
 Fax: +86 21 6485 4899  
 Email support4china@watson-marlow.co.uk

**France**  
 Telephone +33 (0) 2 37 38 92 03  
 Fax: +33 (0) 2 37 38 92 04  
 Email info@watson-marlow.fr

**Germany**  
 Telephone +49 (0) 2183 42040  
 Fax: +49 (0) 2183 82592  
 Email info@watson-marlow.de

**Italy**  
 Telephone +39 030 6871184  
 Fax: +39 030 6871352  
 Email info@watson-marlow.it

**Korea**  
 Telephone +82 (0) 2 525 5755  
 Fax: +82 (0) 2 525 5764  
 Email support4k@watson-marlow.co.uk

**Malaysia**  
 Telephone +60 (3) 5635 3323  
 Fax: +60 (3) 5635 7717  
 Email sales@my.SpiraxSarco.com

**Netherlands**  
 Telephone +31 (0) 10 462 1688  
 Fax: +31 (0) 10 462 3486  
 Email info@watson-marlow.nl

**South Africa**  
 Telephone +27 11 794 1921  
 Fax: +27 11 794 1250  
 Email info@wmbpumps.co.za

**Sweden**  
 Telephone +46 8 556 556 00  
 Fax: +46 8 556 556 19  
 Email info@watson-marlow.nu

**United Kingdom**  
 Telephone +44 (0) 1326 370370  
 Fax: +44 (0) 1326 376009  
 Email support@watson-marlow.co.uk

**www.watson-marlow.com**  
 Members of the Spirax-Sarco Engineering Group

The information contained in this document is believed to be correct but Watson-Marlow Bredel accepts no liability for any errors it contains, and reserves the right to alter specifications without notice.



**Pump Series**

**Flow Rates**

Put a peristaltic in your process **Improve your performance**

<b>100</b>	Single channel, low flow pumps. Fixed or variable speed.	1µl/min - 50ml/min
<b>200</b>	Near pulseless, multi-channel pumps with up to 32 channels.	0.5µl/min - 21ml/min
<b>300</b>	Single or multi-channel pumps with manual, remote or dispensing control.	2µl/min - 2 liter/min
<b>400</b>	Instrument-quality, ultra-precise, single and multi-channel pumps with manual or process control.	1µl/min - 730ml/min
<b>500</b>	Superb range of Nema 4X rated pumps for science and industry as well as fixed and variable speed close-coupled pumps	10µl/min - 4.37 liter/min
<b>600</b>	Nema 4X washdown mid-flow process pumps with full CIP and SIP capability. Fixed or variable speed. Operating at pressures up to 60 PSI	0.01 gpm - 4.8 gpm
<b>700</b>	IP55 washdown industrial pumps with manual or auto control, single or twin channel.	0.4 gpm - 17.4 gpm
<b>800</b>	High flow hygienic pumps with full CIP and SIP capability. Operating at pressures up to 100 PSI	0.5 gpm - 35 gpm
<b>SPX</b>	Bredel: High flow industrial pumps operating at pressures up to 230 PSI.	0.08 gpm - 350 gpm

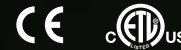
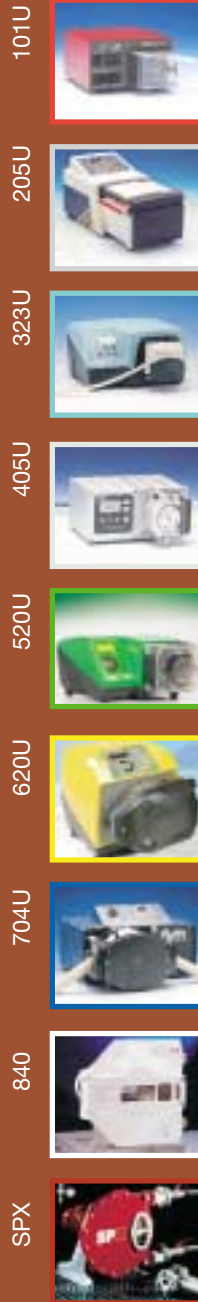

**Watson-Marlow Bredel Pumps**  
**37 Upton Technology Park**  
**Boston, MA 01887**

Telephone: 800 282 8823  
 Fax: 978 658 0041  
 Email: support@wmbpumps.com  
 Web: www.watson-marlow.com

Represented by  
**POWELL**  
 EQUIPMENT SALES, INC  
 (763) 786-2977  
 www.powellequipmentsales.com